



twinnno

T4000 pH/ORP Online Analyzer

Operating Manual



Shanghai Chunye Instrument Technology Co.,Ltd



Shanghai Chunye Instrument Technology Co.,Ltd

Tel: 021-61621082

Fax: 021-61621099

Web: www.twinnno.net

Add: Building 6, No.166 Mindong Road, Pudong New District, Shanghai, China

Post code:201209

Notes

Distinguished users, please pay attention to the following points when using the instrument, in order to ensure the life and accuracy of the instrument.

- ★ Careful handling to avoid collision and falling instruments in use.
- ★ Avoid contact with water or other liquids during use.
- ★ Don't put the instrument in the sunshine for a long time. After use, it should be stored in a cool, dry and ventilated place.
- ★ If you don't use the instrument for a long time, you should unplug the power supply to avoid accidents.
- ★ This instrument is not suitable for use in harsh environment, high temperature, low temperature or strong magnetic field interference, which may lead to instrument damage.
- ★ If there is any problem with the instrument, please contact the dealer or the company. Do not disassemble the instrument by yourself. If disassembled, the company will no longer be responsible for the warranty.

Table of Contents

Preface	1
Features	1
Technical Specifications	2
Installation	3
Installation size	3
Embedded installation	4
Wall mounted installation	4
Electrical connection	5
Keypad descriptions	6
Display descriptions	7
Menu	8
Calibration	10
MODBUS RTU	12
pH Buffer vs Temperature	19
Daily Maintenance	20
Package Set	21
Warranty	22
Notes	23

Preface

Thank you for your support. Please read this manual carefully before use. The correct use will maximize the performance and advantages of the product, and bring you a good experience.

When receiving the instrument, please open the package carefully, check whether the instrument and accessories are damaged by transportation and whether the accessories are complete. If any abnormalities are found, please contact our after-sales service department or regional customer service center, and keep the package for return processing.

This instrument is an analytical measurement and control instrument with highly precision. Only skilled, trained or authorized person should carry out installation, setup and operation of the instrument. Ensure that the power cable is physically separated from the power supply when connection or repair. Once the safety problem occurs, make sure that the power to the instrument is off and disconnected.

For example, it may insecurity when the following situations occur:

- 1) Apparent damage to the analyzer
- 2) The analyzer does not work properly or provides specified measurements.
- 3) The analyzer has been stored for a long time in an environment where the temperature exceeds 70 °C.

The analyzer must be installed by professionals in accordance with relevant local specifications, and instructions are included in the operation manual. Comply with the technical specifications and input requirements of the analyzer.

Features

The instrument is equipped with different types of pH or ORP sensors. Widely used in power plants, petrochemical industry, metallurgical electronics, mining, paper industry, biological fermentation engineering, medicine, food and beverage, environmental protection water treatment, aquaculture, modern agricultural planting and other industries. The pH (acidity and alkalinity) value, ORP (redox potential) value and temperature value of water solution were continuously monitored and controlled.

- Color LCD display
- Intelligent menu operation
- Multiple automatic calibration
- Differential signal measurement mode, stable and reliable
- Manual and automatic temperature compensation
- Two relay control switches
- High & low alarm and hysteresis control
- 4-20mA & RS485, Multiple output modes
- Multi parameter display simultaneously shows – pH/ORP, Temp, current, etc.
- Password protection to prevent misoperation by non-staff.

Warranty

We Instruments warrants this product to be free from significant deviations in material and workmanship for a period of one year from the date of purchase. If repair is necessary and has not been the result of abuse or misuse within the warranty period, please return to We Instruments and amendment will be made without any charge. We Instruments Customer Service Center will determine if product problem is due to deviations or customer abuse. Out of warranty products will be repaired on a charge basis.

Authorization must be obtained from We Instruments Customer Service Center to issue a RIR number before returning items for any reason. When applying for authorization, please include date requiring the reason of return. Instruments must be carefully packed to prevent damage in shipment and insured against possible damage or loss. We Instruments will not be responsible for any damage resulting from careless or insufficient packing.

Warning: Damage as a result of inadequate packaging is the User / distributor's responsibility.

Please follow the guidelines below before transporting.

Use the original packaging material if possible, when transporting back the unit for repair. Otherwise wrap it with bubble pack and use a corrugated box for better protection. Include a brief description of any faults suspected for the convenience of Customer Service Center, if possible. If there are any questions, feel free to contact our Customer Service Center or distributors.

Complete Set

Product Description	Quantity
1) T4000 online PH/ORP Controller	1
2) Instrument embedded bracket, wall mounting bracket	1
3) Operating Manual	1
4) Warranty Card	1

Note: Please check the complete set of instruments before use.
The company's other series of analytical instruments, please login to our website for enquiries.

Technical Specifications

Measuring range	pH:-2~16pH; ORP:-1999~+1999mV
Unit	pH,mV
Resolution	pH:0.01pH; ORP:1mV
Basic error	pH:±0.02pH;ORP:±2mV;
Temperature	0~150.0°C(Depend on the Sensor)
Temperature resolution	0.1°C
Temperature accuracy	±0.3°C
Temperature compensation	0~150.0°C
Temperature compensation	Manual or automatic
Stability	pH:≤0.02pH/24h;ORP: ≤2mV/24h
Current outputs	Two :4~20mA,20~4mA,0~20mA
Communication output	RS485 MODBUS RTU
Two relay control contacts	Two:3A 250VAC,3A 30VDC
Optional power supply	85~265VAC,9~36VDC,power consumption≤3W
Working conditions	No strong magnetic field interference except the geomagnetic field.
Working temperature	-10~60°C
Relative humidity	≤90%
Waterproof rating	IP65
Weight	0.6kg
Dimensions	98×98×130mm
Installation opening size	93×93mm
Installation methods	Panel & wall mounted

Instrument installation

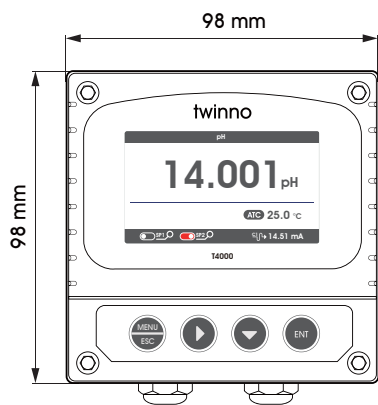

Instrument dimensions

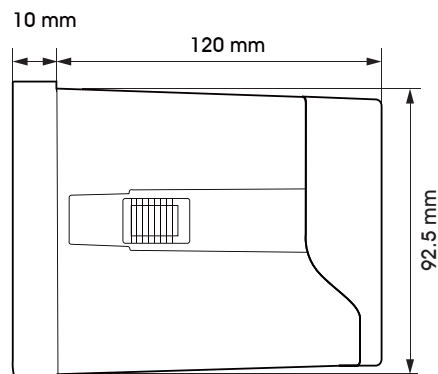

Instrument dimensions(Side view)

Embedded installation

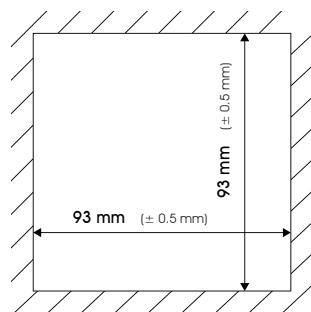

Insert mounting hole size

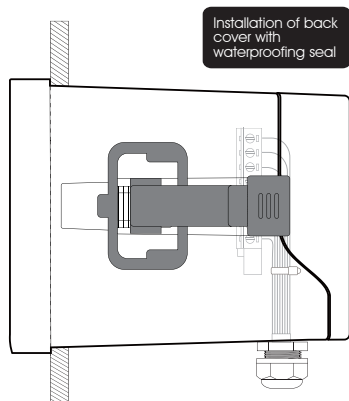

Insert the instrument into the square hole and fix it with the collocated clip.

Daily maintenance

Generally, the instrument does not need daily maintenance. If there is any fault, you can contact our company and carry out adjustment and repair under the guidance of our technical personnel (you can send it back to our company for help or check).

Simple checking method: set the parameter zero potential E0 to 0.0mV, and the slope to 1.00, and then short circuit the terminals of the meter "PH+" and "PH-", and the meter should display 7.00 or within the basic error range; Connect 2K resistance to feet of "29" /TEMP+ and "30" /TEMP, and the temperature of the meter should be displayed around 27.5°C or within the basic error range. If the display is not correct, means the meter is out of working, please contact the manufacturer timely for maintenance.

The sensor electrode maintenance should pay attention to the following points:

- (1) when adopting the circulation structure, the velocity of the inlet water sample should be kept as constant as possible.
- (2) Upon delivery, the electrode head is provided with a protective cap containing electrode soaking liquid to maintain the wetting of sensitive membrane. Take off the protective cap before use and screw on the protective cap when not in use.
- (3) The new electrode can be immersed in 3.3 mKCL solution for 24 hours to ensure the accuracy of calibration.
- (4) It is recommended to calibrate before installation. When installing the measuring pool, the glass bulb of composite electrode should not be collided to avoid damage.
- (5) When the water is cut off on site for a long time without use, the electrode should be screwed on the protective cap in time, and the protective cap should be put into a 3.3m concentration soaking solution, which can not be dried, otherwise it is easy to fail!
- (6) There is dirt on the glass bulb at the top of the electrode, which can be cleaned with 0.1n hydrochloric acid, and then activated after invasion into 3.3mKCl solution. Do not touch it by hand. To ensure long-term correct measurement, the electrode should be cleaned, maintained and calibrated regularly. Antimony electrode will produce oxidation after being used for a period of time, and the electrode head will become black. Fine sandpaper can be used to polish the electrode head and remove the oxidation part, so as to ensure the sensitivity of electrode measurement.
- (7) keep the electrode cable and connector clean and dry, not damp or water.
- (8) The electrode shall be replaced if it fails or is damaged. It is recommended to replace one in a year.

When the electrode is not in use, it should be soaked in the solution.

The preparation of the immersion solution: take a package of pH4 buffer, dissolve it in 250ml pure water, and then add 56g of analytical pure KCl. Heat it properly and stir until it is completely dissolved. (note: the electrode is easy to fail when stored in dry state)

PH buffer vs Temperature

Temp(°C)	pH4.01	pH6.86	pH9.18	pH4.00	pH7.00	pH10.01
0	4.01	6.98	9.47	4.01	7.12	10.32
5	4.01	6.95	9.38	4.00	7.09	10.25
10	4.00	6.92	9.32	4.00	7.06	10.18
15	4.00	6.90	9.27	4.00	7.04	10.12
20	4.00	6.88	9.22	4.00	7.02	10.06
25	4.01	6.86	9.18	4.00	7.00	10.01
30	4.01	6.85	9.14	4.01	6.99	9.97
35	4.02	6.84	9.10	4.02	6.98	9.93
40	4.03	6.84	9.07	4.03	6.97	9.89
45	4.04	6.83	9.04	4.04	6.97	9.86
50	4.06	6.83	9.01	4.06	6.97	9.83
55	4.08	6.83	8.99	4.07	6.97	9.81
60	4.10	6.84	8.96	4.09	6.98	9.79
70	4.12	6.85	8.92	4.12	6.99	9.76
80	4.16	6.86	8.89	4.16	7.00	9.74
90	4.20	6.88	8.85	4.20	7.02	9.73

Wall mounting

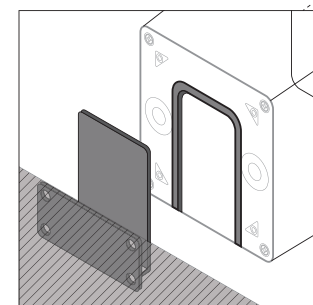
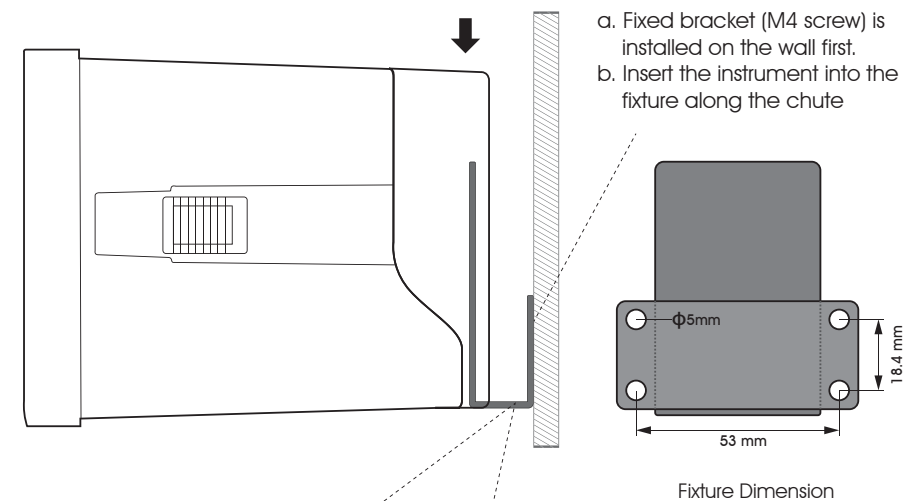

Fixed bracket (M4 screw) is installed on the wall first.

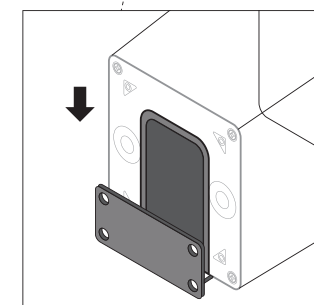

Insert the instrument into the fixture along the chute

Instrument connection

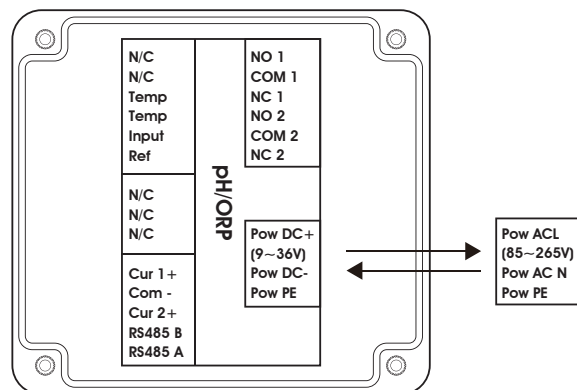

Terminal	Function	Terminal	Function
N/C	No connection	NO 1	High set relay working position
N/C		COM 1	Alarm relay common
Temp	Temperature sensor	NC 1	High set relay resting position
Temp	Temperature sensor	NO 2	Low set relay working position
Input	Measurement	COM 2	Alarm relay common
Ref	Reference	NC 2	Low set relay resting position
N/C			
N/C		Pow DC+ (9~36V)	DC power + (9-36V)
N/C		Pow DC-	DC power -
Cur 1+	Current output 1+	Pow PE	Earth wire
Com -	Current output common terminal		
Cur 2+	Current output 2+	Pow ACL (85~265V)	Live wire
RS485 B	Communication	Pow AC N	Neutral wire
RS485 A	Communication	Pow PE	Earth wire

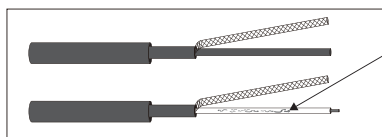

Tip: If the user needs to lengthen or shorten the cable, please remove the black conductive skin outside the transparent wire to prevent short circuit between the black conductive skin and the reference end of the electrode. Multimeter can be used to check, please use special cable for pH connection.

Electrical connection

Connection between instrument and pH or ORP sensors: Connection of power supply, output signal, relay contacts and instrument baseplate. The cable length of sensors is usually 5-10 meters. There are labeled inserts at the end of the cable, which can be inserted into the terminal with the same digital symbols on the instrument roof and tightened.

Read instruction mode

The communication protocol adopts MODBUS (RTU) protocol. The content and address of the communication can be changed according to the needs of customers. The default configuration is network address 01, baud rate 9600, even check, one stop bit, users can set their own changes;

Function code 0x04: This function enables the host to obtain real-time measurements from slaves, which are specified as single-precision floating-point type (i.e. occupying two consecutive register addresses), and to mark the corresponding parameters with different register addresses.

Communication address is as follows:

0000-0001: Temperature value
 0002-0003: Main Measured Value
 0004-0005: Temperature and Voltage Value
 0006-0007: Main Voltage Value

Communication examples:

Examples of function code 04 instructions:

Communication address = 1, temperature = 20.0, ion value = 10.0, temperature voltage = 100.0, ion voltage = 200.0

Host Send: 01 04 00 00 08 F1 CC

Slave Response: 01 04 10 00 41 A0 00 41 20 00 42 C8 00 43 48 81 E8

Note:

[01] Represents the instrument communication address;

[04] Represents function code 04;

[10] represents 10H (16) byte data;

[00 00 00 41 A0] = 20.0; / temperature value

[00 00 41 20] = 10.0; // Main Measured Value

[00 00 42 C8] = 100.0; // Temperature and Voltage Value

[00 00 43 48] = 200.0; // Main measured voltage value

[81 E8] represents CRC16 check code;

If it is large-end storage mode, after executing the above statement, the data stored in outdata of address unit is 0x41
 Outdata + 1 stores data as 0x8D
 address unit (outdata + 2) stores data as 0x00
 address unit (outdata + 3) stores data as 0x00

2. If the compiler used by the user does not implement the library function of this function, the following functions can be used to achieve this function:

```
void memcpy(void *dest,void *src,int n)
{
char *pd = (char *)dest; char *ps = (char *)src;
for(int i=0;i<n;i++) *pd++ = *ps++;
}
```

And then make a call to the above memcpy(outdata,&floatdata,4);

Example: Compile binary floating-point number 0100 0010 0111 1011 0110 0110 0110 10B to decimal number

Step 1: Divide the binary floating-point number 0100 0010 0111 1011 0110 0110 0110 10B into symbol bit, exponential bit and mantissa bit.

0 1000100 11110110110011001100110B
 1-bit sign + 8-bit index + 23-bit tail sign bit S: 0 denotes positive number
 Index position E: $1000100B = 1 \times 2^7 + 0 \times 2^6 + 0 \times 2^5 + 0 \times 2^4 + 0 \times 2^3 + 1 \times 2^2 + 0 \times 2^1 + 0 \times 2^0 = 128 + 0 + 0 + 0 + 0 + 4 + 0 + 0 = 132$

Mantissa bits M: 11110110110011001100110B = 8087142

Step 2: Calculate the decimal number
 $D = (-1)^S \times (1.0 + M/2^{23}) \times 2^{E-127}$
 $= (-1)^0 \times (1.0 + 8087142/2^{23}) \times 2^{132-127}$
 $= 1 \times 1.964062452316284 \times 32 = 62.85$

Reference Code:

```
float floatToDecimal(long int byte0, long int byte1, long int byte2, long int byte3)
{ long int realbyte0,realbyte1,realbyte2,realbyte3; char S;
long int E,M;
```

```
float D;
realbyte0 = byte3; realbyte1 = byte2; realbyte2 = byte1; realbyte3 = byte0;
```

```
if((realbyte0&0x80)==0)
{ S = 0;//positive number }
else { S = 1;//negative number }
E = ((realbyte0<<1)|(realbyte1 &0x80)>>7)-127;
M = ((realbyte1&0x7f)<<8)|(realbyte2<<8)| realbyte3;
D = pow(-1,S)*(1.0 + M/pow(2,23))* pow(2,E);
```

```
return D; }
```

Function description: parameters byte0, byte1, byte2, byte3 represent 4 bytes of binary floating point number (

The decimal number converted from the return value

For example, the user sends the command to get the temperature value and dissolved oxygen value to the probe. The 4 bytes representing the temperature value in the received response frame are 0x00, 0x00, 0x8d and 0x41. Then the user can get the decimal number of the corresponding temperature value through the following call statement.

That is temperature = 17.625.

```
float temperature = floatToDecimal( 0x00, 0x00, 0x8d, 0x41)
```

Keypad descriptions

Keypad operation tips:

Short Press: Short Press means to release the key immediately after pressing. ((Default to short presses if not indicated below)

Long Press: Long Press is to press the button for 3 seconds and then release it.

Press and hold: Press and hold means to press the button, and accelerate after a certain time until the data is adjusted to the user's required value before releasing the button.

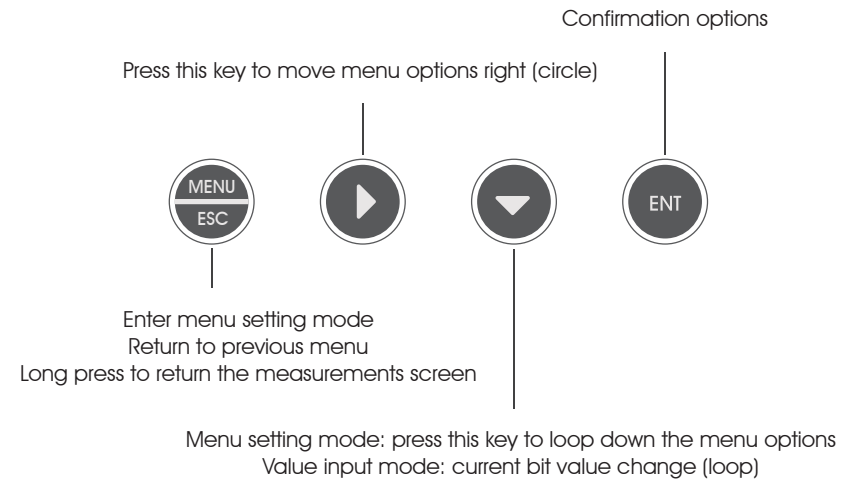

Display descriptions

All pipe connections and electrical connections should be checked before use. After the power is switched on, the meter will display as follows.

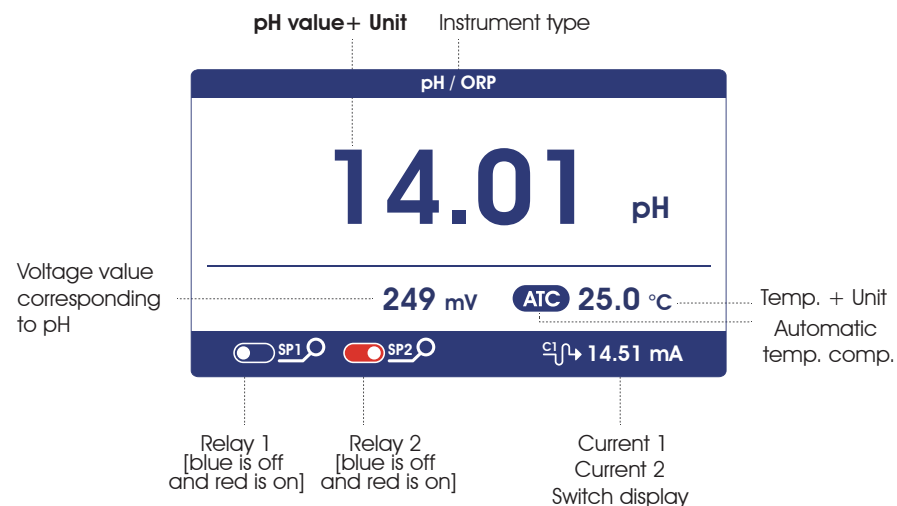

pH measurement mode



ORP measurement mode



Calibration mode



Setting mode

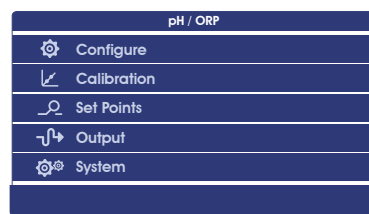

Data format in instrument

Overview

Floating Point

Definition: Floating point, conforming to IEEE 754 (single precision)

Description	Symbol	Index	Mantissa	SUM
Bit	3	30...23	22...0	22...0
Index Deviation		127		

Figure 14: floating point single-precision definition (4 bytes, 2 MODBUS registers)

Example: Compile decimal 17.625 to binary

Step 1: Converting 17.625 in decimal form to a floating-point number in binary form, first finding the binary representation of the integer part

$$17_{\text{decimal}} = 16 + 1 = 1 \times 2^4 + 0 \times 2^3 + 0 \times 2^2 + 0 \times 2^1 + 1 \times 2^0$$

The binary representation of integer part 17 is 10001B

then the binary representation of decimal part is obtained

$$0.625 = 0.5 + 0.125 = 1 \times 2^{-1} + 0 \times 2^{-2} + 1 \times 2^{-3}$$

The binary representation of decimal part 0.625 is 0.101B.

So the binary floating point number of 17.625 in decimal form is 10001.101B

Step 2: Shift to find the exponent.

Move 10001.101B to the left until there is only one decimal point, resulting in 1.0001101B, and

10001.101B = 1.0001101B × 2⁴. So the exponential part is 4, plus 127, it becomes 131, and its binary representation is 10000011B.

Step 3: Calculate the tail number

After removing 1 before the decimal point of 1.0001101B, the final number is 0001101B (because before the decimal point must be 1, so IEEE stipulates that only the decimal point behind can be recorded). For the important explanation of 23-bit mantissa, the first (i.e. hidden bit) is not compiled. Hidden bits are bits on the left side of the separator, which are usually set to 1 and suppressed.

Step 4: Symbol bit definition

The sign bit of positive number is 0, and the sign bit of negative number is 1, so the sign bit of 17.625 is 0.

Step 5: Convert to floating point number

1 bit symbol + 8 bit index + 23-bit mantissa

0 1000011 00011010000000000000000B (the hexadecimal system is shown as 0x418d0000)

Reference code:

1. If the compiler used by the user has a library function that implements this function, the library function can be called directly, for example, using

C language, then you can directly call the C library function memcpy to obtain an integer representation of the floating-point storage format in memory.

For example: float floatdata; // converted floating point number

void* outdata; memcpy(outdata,&floatdata,4);

Suppose floatdata = 17.625

If it is a small-end storage mode, after executing the above statement, the data stored in the address unit outdata is 0x00.

Outdata + 1 stores data as 0x00

address unit (outdata + 2) stores data as 0x8D

address unit (outdata + 3) stores data as 0x41

MODBUS function code 0x10: write multiple registers

This function code is used to write continuous registers to remote devices (1... 123 registers) block that specifies the value of the registers written in the request data frame. Data is packaged in two bytes per register. Response frame return function code, start address and number of registers written.

Request

Function code	1 byte	0x10
Start Address	2 byte	2 byte
Number of input registers	2 byte	2 byte
number of bytes	1 byte	1 byte
Register values	N×2 byte	N×2 byte

N = Register number

Figure 11: Write multiple register request frames

Response

Function code	1 byte	0x10
Start Address	2 byte	0x0000....0xffff
Register number	2 byte	1...123(0x7B)

N = Register number

Figure 12: write multiple register response frames

The request frame and response frame are illustrated below in two registers that write the values 0x000A and 0x0102 to the start address of 2.

Request Frame	(Hexadecimal)	Response Frame	(Hexadecimal)
Number Systems	0x10	Number Systems	0x10
Function code	0x00	Function code	0x00
Start address (high byte)	0x01	Start address (high byte)	0x01
Start address (low byte)	0x00	Start address (low byte)	0x00
Input register number (high bytes)	0x02	Input register number (high bytes)	0x02
Input register number (low bytes)	0x04	Input register number (low bytes)	
number of bytes	0x00		
Register value (high byte)	0x0A		
Register value (low byte)	0x01		
Register value (high byte)	0x02		
Register value (low byte)			

Figure 13: Examples of writing multiple register request and response frames

Menu structure

The following is the menu structure of this instrument, press **[MENU]** key to enter menu setting mode:

If the monitor prompts you to enter the calibration security password, press the **[▼]** key or **[▶]** key to set the calibration security password, and then press the **[ENT]** key to confirm the calibration security password. No initial password here, please enter directly by press **[ENT]** key.

Configure	Sensor	Type	PH	
		Unit	ORP pH mV	
	Temperature	Temperature Sensor	NTC2.252 kΩ NTC10 kΩ Pt100 Pt1000	
		Temperature Offset	0.0000	
		Temperature Input	Automatic Manual	
		Temperature Unit	°C °F	
	Calibration	Standard Calibration	USA: 7.00, 4.01, 10.01	Automatic identification, calibrate 7.00 first
			NIST: 6.86, 4.01, 9.18	Automatic identification, calibrate 6.86 first
			ORP Standard Solution	235mV(Default)
Correction			Offset 1 Slope 1 Offset 2 Slope 2	
Field Calibration		Field Calibration		
		Offset1 Adjustment		
		Slope1 Adjustment		
		Offset2 Adjustment Slope2 Adjustment		
Alarm		Relay 1	Status	ON OFF
			High/Low Setpoint	High Alarm Low Alarm
	Limit Value			
	Hysteresis			
	Relay 2	Status	ON OFF	
		High/Low Setpoint	High Alarm Low Alarm	
		Limit Value		
		Hysteresis		

Output	Current 1	Channel	Main
			Temperature
		Output Option	4-20mA
			0-20mA
			20-4mA
	Upper Limit		
	Lower Limit		
	Current 2	Channel	Main
			Temperature
		Output Option	4-20mA
			0-20mA
			20-4mA
	Upper Limit		
	Lower Limit		
	RS485	Baud Rate	4800BPS
9600BPS			
19200BPS			
Parity Check		None	
		Odd	
		Even	
Stop Bit		1 Bit	
	2 Bit		
Network Node			
System	Language	Chinese	
		English	
	Display	Display Speed	Low
			Standard
			Medium
			High
		Backlight	Saving
	Bright		
	Soft Version	Soft Version	19-1.0
		Password Settings	0000
		Serial Number	
	Factory Default	1.No	
		2.Yes	
	Terminal Current Tuning	Current 1 4mA	(The positive and negative ends of the ammeter are connected to the current 1 or current 2 output terminals of the instrument respectively, press 【▼】key to adjust the current to 4 mA or 20mA ,press【ENT】key to confirm.)
		Current 1 20mA	
Current 2 4mA			
Current 2 20mA			
Relay Test	Relay 1	(Select two relays and hear the relay switch twice sounds, indicate the relay is normal.)	
	Relay 2		

Implementation of MODBUS RTU in Instrument

According to the official MODBUS definition, the command starts with a 3.5 character interval triggering command, and the end of the command is also represented by a 3.5 character interval. The device address and MODBUS function code have 8 bits. The data string contains n*8 bits, and the data string contains the starting address of the register and the number of read/write registers. CRC check is 16 bits.

Value	Start	Device address	Function	Data	Summary Check	End
	No signal bytes during 3.5 characters	1-247 1	Function codes conforming to MODBUS specification	Data conforming to MODBUS specification	CRCL CRCL	No signal bytes during 3.5 characters
Byte	3.5		1	n	1 1	3.5

Figure 7: MODBUS definition of data transmission

Instrument MODBUS RTU function code

The instrument only uses two MODBUS function codes:

0x03: Read-and-hold register

0x10: Write multiple registers

MODBUS Function Code 0x03: Read-and-hold Register

This function code is used to read the continuous block content of the holding register of the remote device. Request the PDU to specify the start register address and the number of registers. Address registers from zero. Therefore, the addressing register 1-16 is 0-15. The register data in the response information is packaged in two bytes per register. For each register, the first byte contains high bits and the second byte contains low bits.

Request

Function code	1 byte	0x03
Start Address	2 byte	0x0000...0xffff
Read register number	2 byte	1...125

Figure 8: Read-and-hold register request frame

Response

Function code	1 byte	0x03
number of bytes	1 byte	N×2
Register values	N×2 byte	

N = Register number

Figure 9: Read-and-hold register response frame

The following illustrates the request frame and response frame with the read and hold register 108-110 as an example. (The contents of register 108 are read-only, with two byte values of 0X022B, and the contents of register 109-110 are 0X0000 and 0X0064)

Request Frame	(Hexadecimal)	Response Frame	(Hexadecimal)
Number Systems		Number Systems	
Function code	0x03	Function code	0x03
Start address (high byte)	0x00	Byte count	0x06
Start address (low byte)	0x6B	Register Value (High Bytes) (108)	0x02
Number of Read Registers (High Bytes)	0x00	Register Value (Low Bytes)(108)	0x2B
Number of Read Registers (Low Bytes)	0x03	Register Value (High Bytes) (109)	0x00
		Register Value (Low Bytes) (109)	0x00
		Register Value (High Bytes)(110)	0x00
		Register Value (Low Bytes) (110)	0x64

Figure 10: Examples of read and hold register request and response frames

MODBUS RTU Transmission Mode

When the instrument uses RTU (Remote Terminal Unit) mode for MODBUS serial communication, each 8-bit byte of information contains two 4-bit hexadecimal characters. The main advantages of this mode are greater character density and better data throughput than the ASCII mode with the same baud rate. Each message must be transmitted as a continuous string.

The format of each byte in RTU mode (11 bits):

Coding system: 8-bit binary

Each 8-bit byte in a message contains two 4-bit hexadecimal characters (0-9, A-F)

Bits in each byte: 1 starting bit

8 data bits, the first minimum valid bits without parity check bits

2 stop bits

Baud rate: 9600 BPS

How characters are transmitted serially:

Each character or byte is sent in this order (from left to right) the least significant bit (LSB)... Maximum Significant Bit (MSB)

Start bit	1	2	3	4	5	6	7	8	Stop bit	Stop bit
-----------	---	---	---	---	---	---	---	---	----------	----------

Figure 3: RTU pattern bit sequence

Check Domain Structure: Cyclic Redundancy Check (CRC16)

Structure description:

Slave Instrument	Function Code	Data	CRC	
Address	1 byte	0...252 byte	2 byte	
			CRC Low byte	CRCHigh byte

Figure 4: RTU information structure

The maximum frame size of MODBUS is 256 bytes

MODBUS RTU Information Frame

In RTU mode, message frames are distinguished by idle intervals of at least 3.5 character times, which are called t3.5 in subsequent sections.

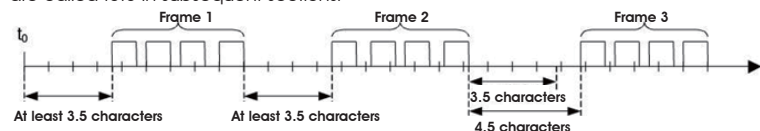

Starting	Address	Function code	Data	CRC check	End
≥3.5 characters	8 bit	8 bit	Nx8 bit	16 bit	≥3.5 characters

Figure 5: RTU message frame

The entire message frame must be sent in a continuous character stream.

When the pause time interval between two characters exceeds 1.5 characters, the information frame is considered incomplete and the receiver does not receive the information frame.

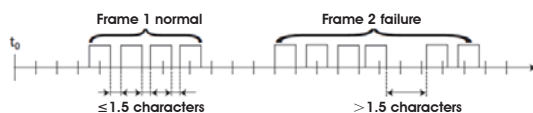

MODBUS RTU CRC Check

The RTU mode contains an error-detection domain based on a cyclic redundancy check (CRC) algorithm that performs on all message contents. The CRC domain checks the contents of the entire message and performs this check regardless of whether the message has a random parity check. The CRC domain contains a 16-bit value consisting of two 8-bit bytes. CRC16 check is adopted..Low bytes precede, high bytes precede.

Calibration

Press [MENU] to enter the setting mode and select the calibration

Calibration	Standard Calibration	USA:7.00,4.01,10.01	Automatic identification, calibrate 7.00 first
		NIST:6.86,4.01,9.18	Automatic identification, calibrate 6.86 first
		ORP Standard Solution	235mV(Default)
Field Calibration	Field Calibration	Field Calibration	
		Offset Adjustment	
		Slope Adjustment	

Calibration of Standard Solution

Select the Standard Solution Calibration, a total of two groups: USA: 7.00, 4.01, 10.01 and NIST: 6.86, 4.01, 9.18. After the selection is completed, press the [ENT] button to confirm and enter the standard solution calibration mode.

If the instrument has been calibrated, the screen shows the calibration status and then press the [ENT] key again to enter the re-calibration if you need re-calibration.

If the monitor prompts you to enter the calibration security password, press the [▼] key or [▶] key to set the calibration security password, and then press the [ENT] key to confirm the calibration security password.

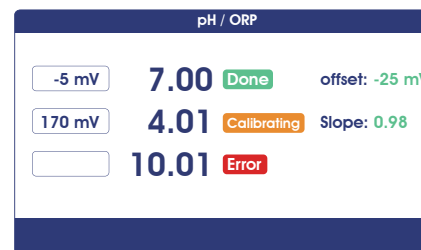

PH Calibration



ORP Calibration

PH Calibration: After entering the calibration mode, the instrument displays as shown above.

The instrument automatically identifies the standard liquid, first calibrates the midpoint (example 7.00pH), then calibrates 4.01pH or 10.01pH. The corresponding mV value will be displayed on the left side of the screen.

After the calibration is completed, the offset and slope will be displayed on the right side of the screen.

If only two points of calibration are needed, after two points of calibration, press the [Menu] button to exit directly.

During the calibration process, **Error** prompt appears on the screen when the standard liquid is wrong.

Calibration results: The slope of glass electrode (> 0.90) is qualified, and that of metal antimony electrode (> 0.80) is qualified.

ORP Calibration: Press **[Menu]** key to enter the setting mode, select ORP standard liquid calibration, and input the known standard liquid value (default 235mV), press the **[ENT]** key to enter the standard solution calibration mode.

If the instrument has been calibrated, the screen shows the calibration status and then press the **[ENT]** key again to enter the re-calibration if you need re-calibration.

After entering the calibration mode, the instrument will be displayed as the upper right image, and the corresponding mV value will be displayed on the left side of the screen.

After the calibration is completed, the slope will be displayed on the right side of the screen.

The pH value of buffer solution was measured at 25°C.

To calibrate the instrument using an automatic identification buffer, you need a standard pH buffer that matches any of these values. Before using automatic calibration, please select the correct buffer table (see "Buffer Table").

Before calibration, the sensor can be activated in the pH sensor immersion solution to ensure the stability and accuracy of calibration and monitoring values.

Field Calibration

Select on-site calibration methods: **[Linear calibration]**, **[Offset adjustment]**, **[linear adjustment]**.

Field Calibration

When the data from laboratory or portable instrument are input into this item, the instrument will automatically correct the data.

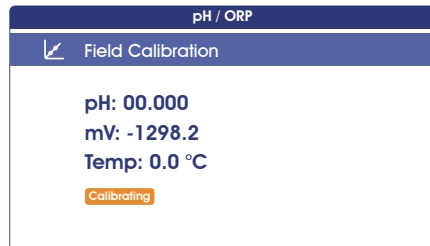

Offset adjustment

Compare the data of laboratory or portable instrument with the data of instrument measurement, if there are errors, the error data can be modified by this function.

Linear adjustment

Linear values after "field calibration" are stored in this item, with factory data of 1.00.

MODBUS RTU General Information

Overview

The hardware version number of this document is V2.0; the software version number is V5.9 and above. This document describes the MODBUS RTU interface in details and the target object is a software programmer.

MODBUS command structure

Data format description in this document;

Binary display, suffix B, for example: 10001B

- decimal display, without any prefix or suffix, for example: 256

Hexadecimal display, prefix 0x, for example: 0x2A

ASCII character or ASCII string display, for example: "YL0114010022"

Command Structure

The MODBUS application protocol defines the Simple Protocol Data Unit (PDU), which is independent of the underlying communication layer.



Figure 1: MODBUS Protocol Data Unit

MODBUS protocol mapping on a specific bus or network introduces additional fields of protocol data units. The client that initiates the MODBUS exchange creates the MODBUS PDU, and then adds the domain to establish the correct communication PDU.

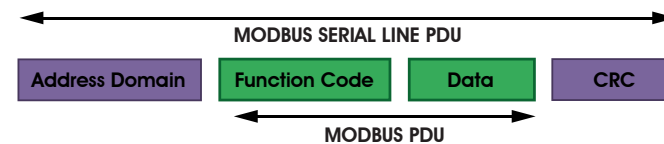

Figure 2: MODBUS architecture for serial communication

On the MODBUS serial line, the address domain contains only the slave instrument address. Tips: The device address range is 1...247

Set the device address of the slave in the address field of the request frame sent by the host.

When the slave instrument responds, it places its instrument address in the address area of the response frame so that the master station knows which slave is responding.

Function codes indicate the type of operation performed by the server.

CRC domain is the result of the "redundancy check" calculation, which is executed according to the information content.