



twinnno 天诺

T6546 On-line Dissolved Oxygen Meter

Fluorescence

Operating Manual



上海淳业仪表科技有限公司
Shanghai Chunye Instrument Technology Co.,Ltd

Contents

Perface	1
Features	2
Specifications	3
Installations	4
Wall-mounted	4
Instrument connection	5
Keypad descriptions	6
Display description	7
Menu structure	8
Calibration	10
Curve query	12
MODBUS RTU General Information	13
Oxygen Saturation Table Under Different Temperatures	20
Daily Maintance	21
Package set	21
Warranty	22
Notes	23

Preface

Thank you for your support. Please read this manual carefully before use. The correct use will maximize the performance and advantages of the product, and bring you a good experience.

When receiving the instrument, please open the package carefully, check whether the instrument and accessories are damaged by transportation and whether the accessories are complete. If any abnormalities are found, please contact our after-sales service department or regional customer service center, and keep the package for return processing.

This instrument is an analytical measurement and control instrument with highly precision. Only skilled, trained or authorized person should carry out installation, setup and operation of the instrument. Ensure that the power cable is physically separated from the power supply when connection or repair. Once the safety problem occurs, make sure that the power to the instrument is off and disconnected.

For example, it may insecurity when the following situations occur:

- 1) Apparent damage to the analyzer
- 2) The analyzer does not work properly or provides specified measurements.
- 3) The analyzer has been stored for a long time in an environment where the temperature exceeds 70 °C.

The analyzer must be installed by professionals in accordance with relevant local specifications, and instructions are included in the operation manual. Comply with the technical specifications and input requirements of the analyzer.

Features

Online Dissolved oxygen meter is a microprocessor-based water quality online monitoring control instrument. It is widely used in drinking water treatment plants, drinking water distribution networks, swimming pools, water treatment projects, sewage treatment, water

disinfection and other industrial processes. It continuous monitoring and control DO and temperature value in aqueous solution.

- Color LCD display
- Intelligent menu operation
- Multiple automatic calibration function
- Manual and automatic temperature compensation
- Three relay control switches
- High & low alarm and hysteresis control
- 4-20mA & RS485, Multiple output modes
- Multi parameter display simultaneously shows –Dissolved oxygen, Temp, current, etc.
- Password protection function to prevent misoperation by non-staff.

Technical Specifications

Measurement range	0~20.00mg/L; 0~200.0%;
Measurement unit	mg/L %
Resolution	0.01mg/L; 0.1%
Basic error	±1%F.S
Temperature	0~50℃
Temperature Resolution	0.1℃
Temperature Basic error	±0.3℃
Current outputs	Two 4~20mA,20~4mA,0~20mA
Signal output	RS485 MODBUS RTU
Other functions	Data record &Curve display
Relay control contacts	3 Group: 5A 250VAC,5A 30VDC
Optional power supply	85~265VAC,9~36VDC,power consumption≤3W
Working conditions	There is no strong magnetic interference besides the earth
Working temperature	-10~60℃
Relative humidity	≤90%
Waterproof rating	IP65
Weight	1.5 kg
Dimensions	235×185×120mm
Installation	Wall mounted

Installations

Installation size

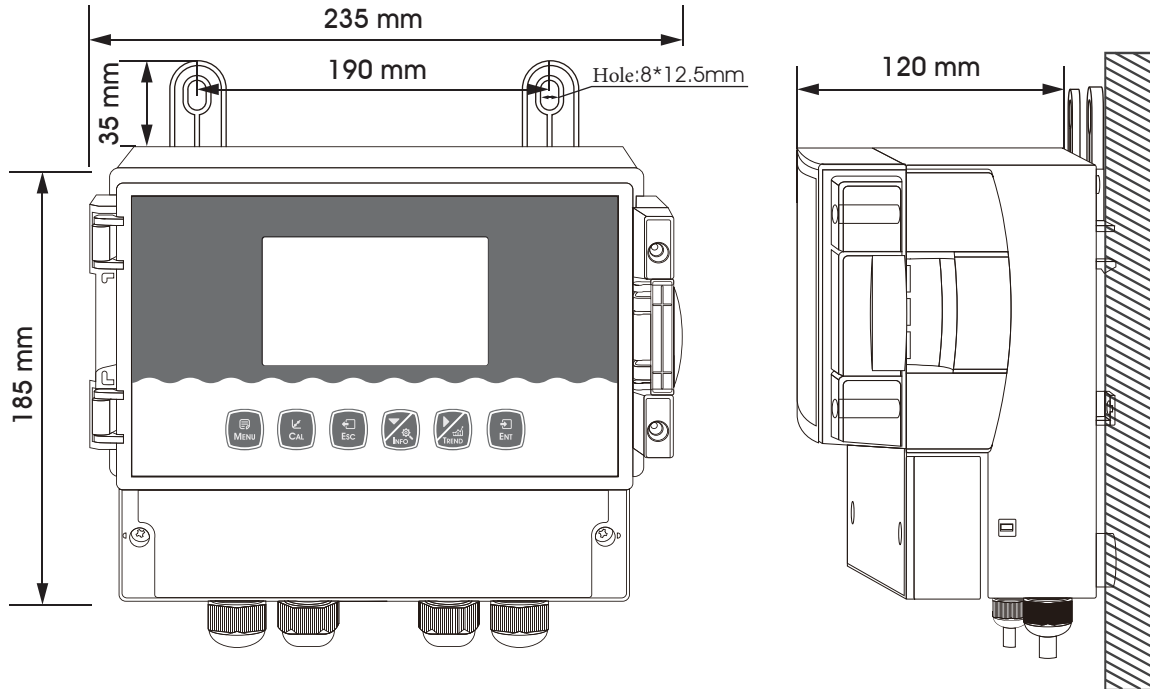

Instrument shape, wall - mounted fixed piece size

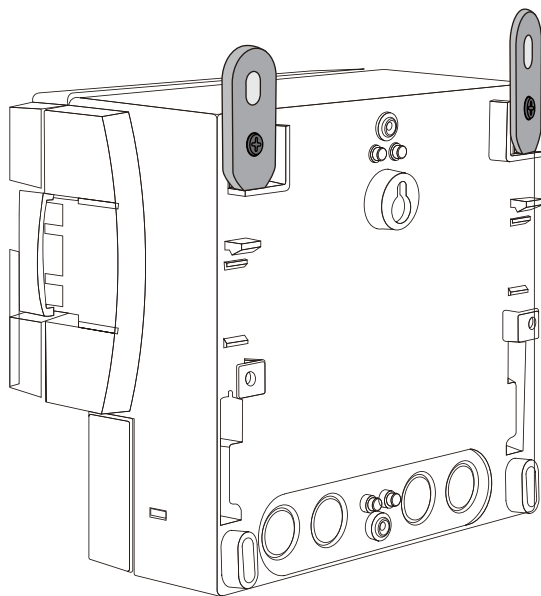

Fix the fixed piece of the instrument

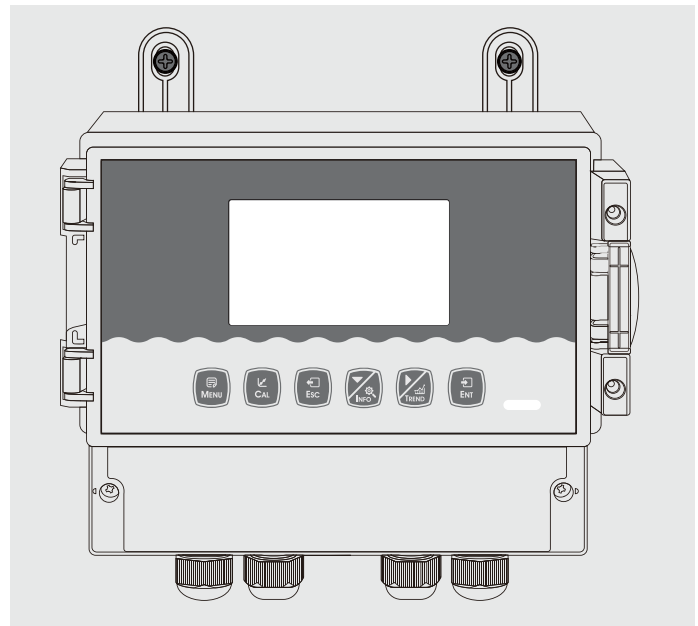

Installation completion drawing

Instrument connection

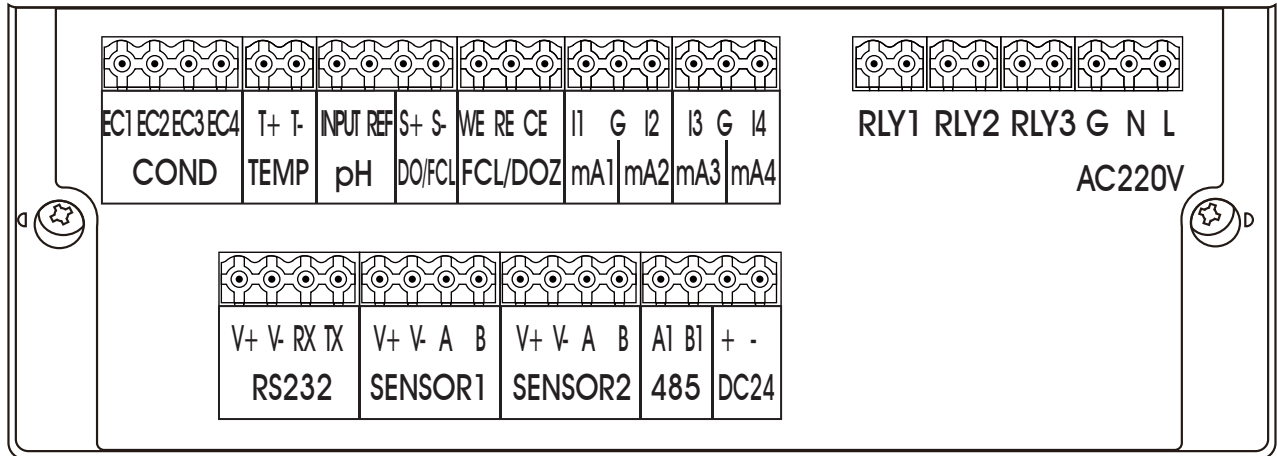

EC1,EC2,EC3,EC4	Electrical conductivity/resistivity wiring	RLY1 RLY2 RLY3	3 groups of relay
T+,T-	Temperature connection	G,L,N	G-ground wire, L-live, -neutral
INPUT	pH/ORP/Ion measure		
REF	pH/ORP/Ion reference	V+,V-,RX,TX	RS232 communication output
S+,S-	Membrane dissolved oxygen, FCL	V+,V-,A,B	Digital input channel 1
CE,RE,WE	Constant voltage residual chlorine/ chlorine dioxide/ozone	V+,V-,A,B	Digital input channel 2
I1,G,I2	Output current	A1,B1	RS485 communication output
I3,G,I4	Input current	+,-	DC power supply

The connection between the instrument and the sensor: the power supply, output signal, relay alarm contact and the connection between the sensor and the instrument are all inside the instrument, and the wiring is as shown above. The length of the cable lead fixed by the electrode is usually 5-10 Meters, insert the corresponding label or color wire on the sensor into the corresponding terminal inside the instrument and tighten it.

Keypad descriptions

Keypad operation tips:

Short Press: Short Press means to release the key immediately after pressing. ((Default to short presses if not indicated below)

Long Press: Long Press is to press the button for 3 seconds and then release it.

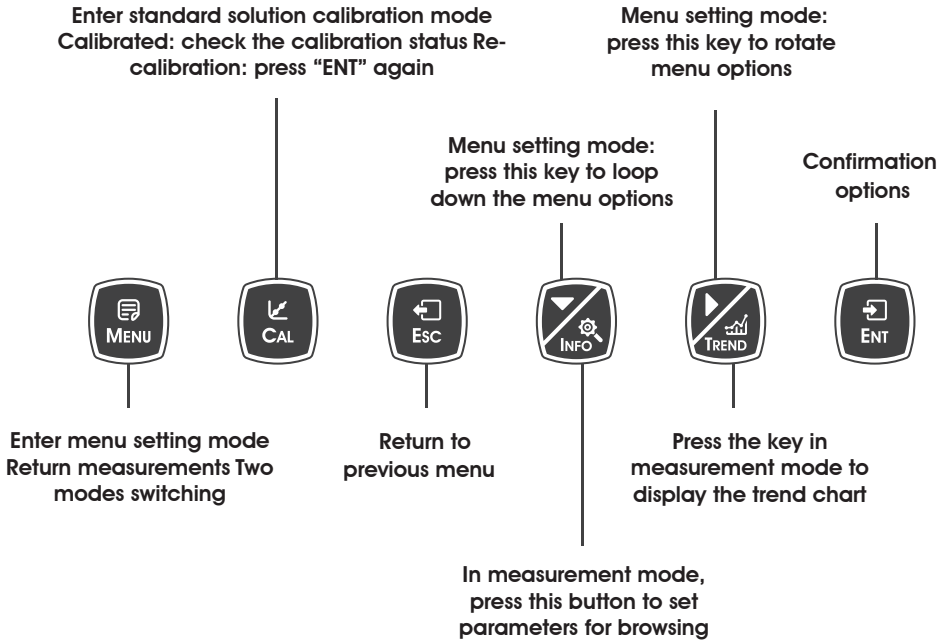

Display descriptions

All pipe connections and electrical connections should be checked before use.
After the power is switched on, the meter will display as follows.

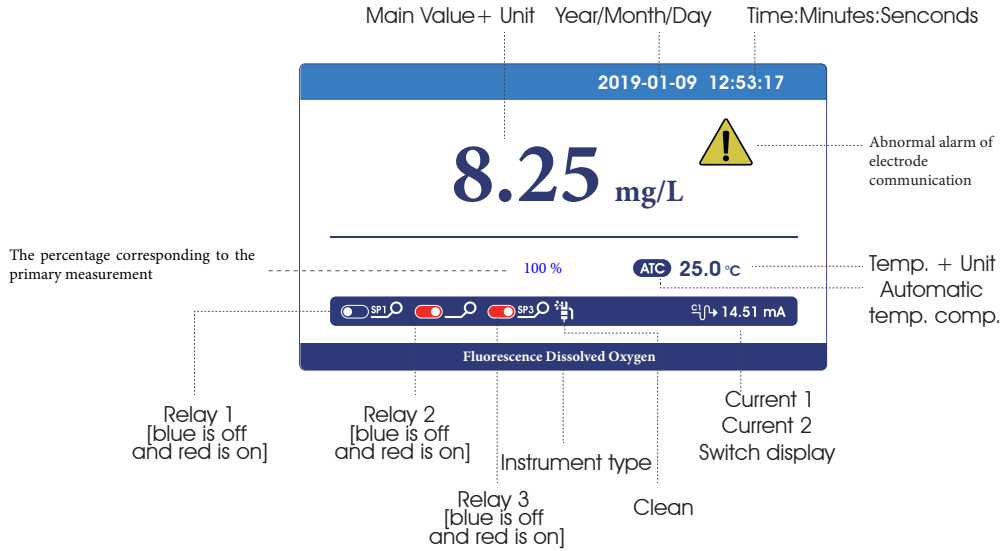

Measurement mode

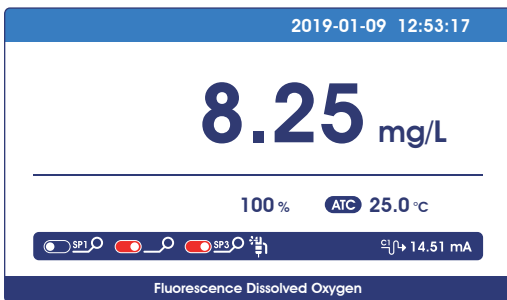

Setting mode



Calibration mode

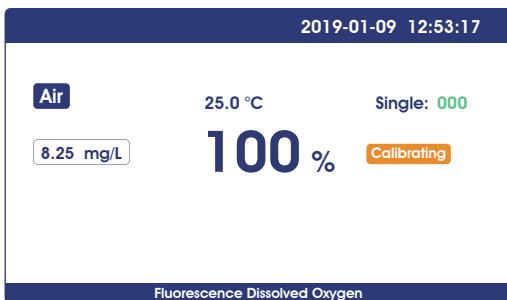

Trend Chart Display

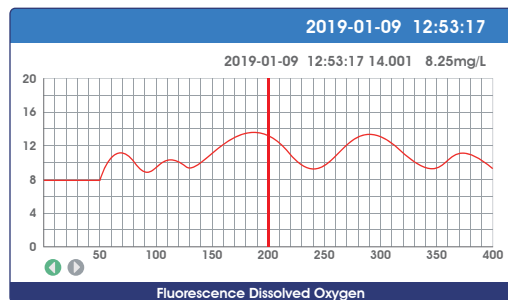

Menu structure

The following is the menu structure of this instrument

Configure	Sensor	Unit	Mg/L	
			%	
		Pressure compensation	101.3	
		Salinity compensation	0	
		Zero oxygen voltage compensation	100mV	
		Saturation oxygen voltage compensation	400mV	
	Temperature	Temperature Sensor		8.25
				NTC2.252 kΩ
				NTC10 kΩ
				Pt100
		Temperature Offset	Pt1000	0.0000
		Temperature Input	Automatic	
			Manual	
		Temperature Unit	°C	
°F				
Calibration	Standard Calibration	Zero calibration		
		Air Calibration		
	Field Calibration	Correction	Offset correction 1	
			Slope correction 2	
		Field Calibration	Offset correction 1	
			Slope correction 2	
Alarm	Relay 1	Status	ON	
			OFF	
		High/Low Alarm	High Alarm	
			Low Alarm	
		Limit Value (Cycle) -under cleaning status	Cleanning(Cleaning time setting is as below) (Continuous opening time)	
		Hysteresis (INterval) -under cleanning status	(The interval between the last opening and closing and the next opening)	
	Relay 2	Status	ON	
			OFF	
		High/Low Alarm	High Alarm	
			Low Alarm	
		Limit Value (Cycle) -under cleaning status	Cleanning(Cleaning time setting is as below) (Continuous opening time)	
		Hysteresis (INterval) -under cleanning status	(The interval between the last opening and closing and the next opening)	
Relay 3	Status	ON		
		OFF		
	High/Low Alarm	High Alarm		
		Low Alarm		
	Limit Value (Cycle) -under cleaning status	Cleanning(Cleaning time setting is as below) (Continuous opening time)		
	Hysteresis (INterval) -under cleanning status	(The interval between the last opening and closing and the next opening)		

Output	Current 1	Channel	Main	
			Temperature	
		Output Option	4-20mA	
			0-20mA	
			20-4mA	
		Upper Limit		
		Lower Limit		
	Current 2	Channel	Main	
			Temperature	
		Output Option	4-20mA	
			0-20mA	
			20-4mA	
		Upper Limit		
		Lower Limit		
	RS485	Baud Rate	4800BPS	
9600BPS				
19200BPS				
Parity Check		None		
		Odd		
		Even		
Stop Bit		1 Bit		
	2 Bit			
Network Node	001 +			
Data Log	Graphic Trend (trend chart)	Interval/point		
		1h/point		
		12h/point		
		24h/point		
	Data Query Interval	year/month/day		
		7.5s		
		90s		
		180s		
Data Output				
Memory information	176932point			
System	Language	Chinese		
		English		
	Date/Time	Year-Month-Day		
		Hour-Minute-Second		
	Display	Display Speed	Low	
			Standard	
			Medium	
			High	
		Backlight	Saving	
		Bright		
	Soft Version	Soft Version	19-1.0	
		Password Settings	0000	
		Serial Number		
	Factory Default	No		
		Yes		
Terminal Current Tuning	Current 1 4mA	(The positive and negative ends of the ammeter are connected to the current 1 or current 2 output terminals of the instrument respectively, press 【▼】 key to adjust the current to 4 mA or 20mA ,press 【ENT】 key to confirm.)		
	Current 1 20mA			
	Current 2 4mA			
	Current 2 20mA			
Relay Test	Relay 1	(Select three groups of relays and hear the sound of two switches, the relay is normal.)		
	Relay 2			
	Relay 3			

Calibration

Press [MENU] to enter the setting mode and select the calibration

Calibration	Standard Calibration	Anaerobic calibration
		Air calibration
		Field Calibration
Field Calibration	Offset Adjustment	
	Slope Adjustment	

Standard Solution Calibration

Select the Standard Solution Calibration, press the **ENT** key to confirm and enter the standard solution calibration mode.

If the instrument has been calibrated, the screen shows the calibration status and then press the **ENT** key again to enter the re-calibration if you need re-calibration.

If the monitor prompts you to enter the calibration security password, press the **ENT** key or **V** key to set the calibration security password, and then press the **ENT** key to confirm the calibration security password.

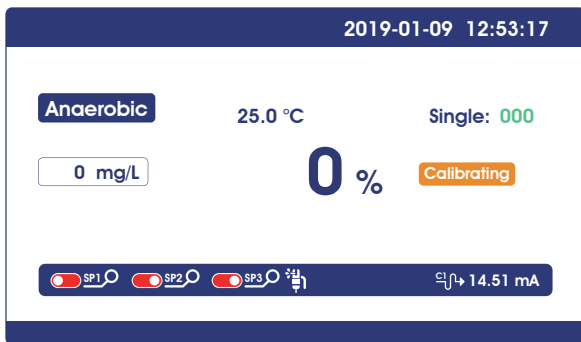

Anaerobic calibration: place probe in anaerobic water without shading cap

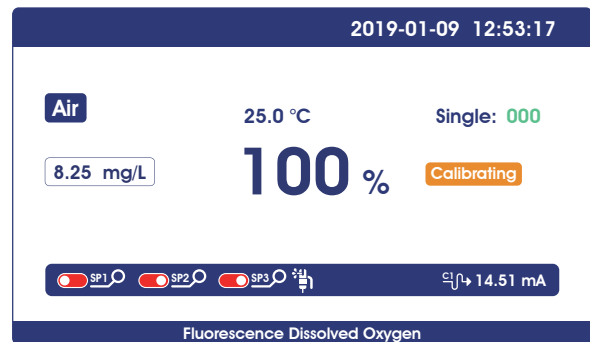

Air calibration: put probe in the air with shade cap

Anaerobic calibration: After entering the calibration mode, the instrument shows as above. DO electrode is put into anaerobic water without shading cap.

The corresponding "signal" value will be displayed in the upper left corner of the screen. When the "signal" value is stable, press **ENT** to confirm.

During the calibration process, the right side of the screen will display the calibration status. **Done** indicates that the calibration was successful, **Calibrating** indicates that in the calibration, **Err** indicates that the calibration failed.

After the calibration is completed, press the Menu key to return to the superior menu.

Air calibration: after entering the calibration mode, the instrument is displayed as shown in the figure above.

Put the DO electrode in the air with the shading cap.

The corresponding "signal" value will be displayed in the upper left corner of the screen. When the "signal" value is stable, press **ENT** to confirm.

During the calibration process, the right side of the screen will display the calibration status. **Done** indicates that the calibration was successful, **Calibrating** indicates that in the calibration, **Err** indicates that the calibration failed.

After the calibration is completed, press the Menu key to return to the superior menu.

Field Calibration

Select on-site calibration methods: [Linear calibration], [Offset adjustment], [Linear adjustment].

Field Calibration

When the data from laboratory or portable instrument are input into this item, the instrument will automatically correct the data.

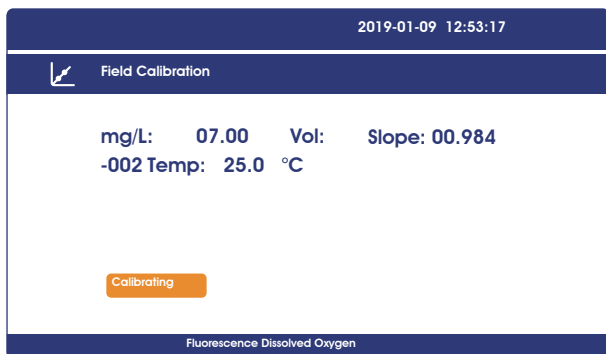

Calibration results:

Confirm: When the "ENT" icon is green, press [ENT] to confirm.

Cancel: Press the [V] key to shift the green icon to ESC, and press [ENT] key to confirm.

Offset adjustment

Compare the data of laboratory or portable instrument with the data of instrument measurement, if there are errors, the error data can be modified by this function.

Linear adjustment

Linear values after "field calibration" are stored in this item, with factory data of 1.00.

Graphic Trend(Trend Chart)

Press **Menu** key to enter the setting mode, set the recording interval, and the instrument will

Data Log	Curve query (trend chart)	Interval/point	400 points per screen, displays the most recent data trend graph according to interval Settings
		1h/point	400 points per screen, display trend chart of the last 16 days of data
		12h/point	400 points per screen, display trend chart of the last 200 days of data
		24h/point	400 points per screen, display trend chart of the last 400 days of data
	Data Query	year/month/day	Year/month/day time: minute: second value unit
Interval	7.5s	Store data every 7.5 seconds	
	90s	Store data every 90 seconds	
	180s	Store data every 180 seconds	

Press the **[MENU]** button returns to the measurement screen. Press the **[V / TREND]** button in the measurement mode to view the trend chart of the saved data directly. There are 480 sets of data record per screen, and the interval time of each record can be selected [7.5s, 90s, 180s], corresponding to the data displayed in [1h, 12h, 24h] per screen.

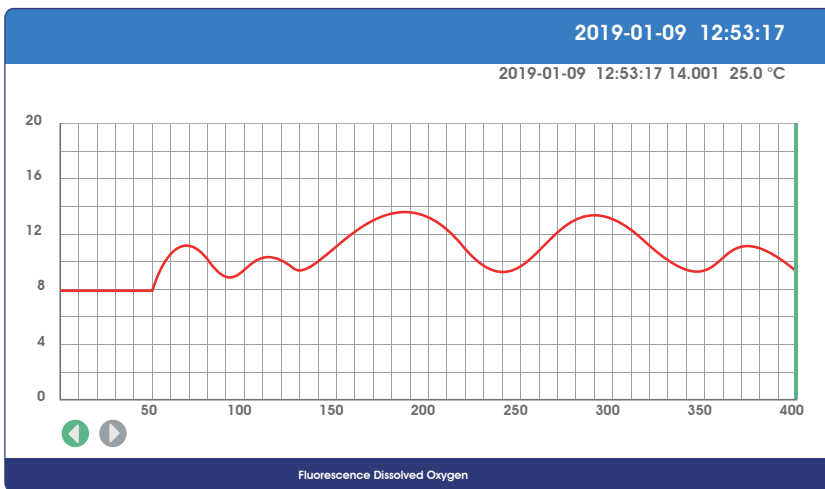

In the current mode, press the **[ENT]** key to move the data display line to the left and right (green), and display the data in left and right circles. Long pressing of the **[ENT]** key can accelerates displacement. (When the bottom icon is green, **[ENT]** key is displacement direction, press

[V / TREND] key to switch the direction of displacement) 

MODBUS RTU General Information

Overview

The hardware version number of this document is V2.0; the software version number is V5.9 and above. This document describes the MODBUS RTU interface in details and the target object is a software programmer.

MODBUS command structure

Data format description in this document;
Binary display, suffix B, for example: 10001B
- decimal display, without any prefix or suffix, for example: 256
Hexadecimal display, prefix 0x, for example: 0x2A
ASCII character or ASCII string display, for example: "YL0114010022"

Command Structure

The MODBUS application protocol defines the Simple Protocol Data Unit (PDU), which is independent of the underlying communication layer.



Figure 1: MODBUS Protocol Data Unit

MODBUS protocol mapping on a specific bus or network introduces additional fields of protocol data units. The client that initiates the MODBUS exchange creates the MODBUS PDU, and then adds the domain to establish the correct communication PDU.

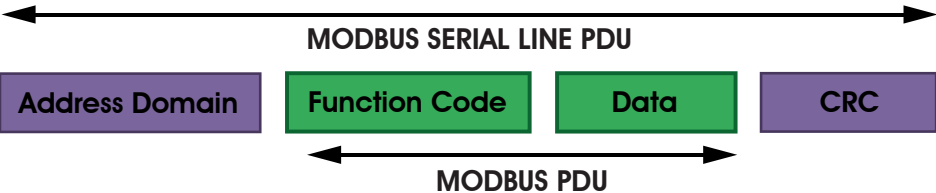

Figure 2: MODBUS architecture for serial communication

On the MODBUS serial line, the address domain contains only the slave instrument address. Tips:
The device address range is 1...247
Set the device address of the slave in the address field of the request frame sent by the host.
When the slave instrument responds, it places its instrument address in the address area of the response frame so that the master station knows which slave is responding.
Function codes indicate the type of operation performed by the server.
CRC domain is the result of the "redundancy check" calculation, which is executed according to the information content.

MODBUS RTU Transmission Mode

When the instrument uses RTU (Remote Terminal Unit) mode for MODBUS serial communication, each 8-bit byte of information contains two 4-bit hexadecimal characters. The main advantages of this mode are greater character density and better data throughput than the ASCII mode with the same baud rate. Each message must be transmitted as a continuous string.

The format of each byte in RTU mode (11 bits):

Coding system: 8-bit binary

Each 8-bit byte in a message contains two 4-bit hexadecimal characters (0-9, A-F)

Bits in each byte: 1 starting bit

8 data bits, the first minimum valid bits without parity check bits

2 stop bits

Baud rate: 9600 BPS

How characters are transmitted serially:

Each character or byte is sent in this order (from left to right) the least significant bit (LSB)... Maximum Significant Bit (MSB)

Start bit	1	2	3					8	Stop bit	Stop bit
-----------	---	---	---	--	--	--	--	---	----------	----------

Figure 3: RTU pattern bit sequence

Check Domain Structure: Cyclic Redundancy Check (CRC16)

Structure description:

Slave Instrument	Function Code	Data	CRC	
Address	1 byte	0...252 byte	2 byte	
			CRC Low byte	CRCHi

Figure 4: RTU information structure

The maximum frame size of MODBUS is 256 bytes

MODBUS RTU Information Frame

In RTU mode, message frames are distinguished by idle intervals of at least 3.5 character times, which are called t3.5 in subsequent sections.

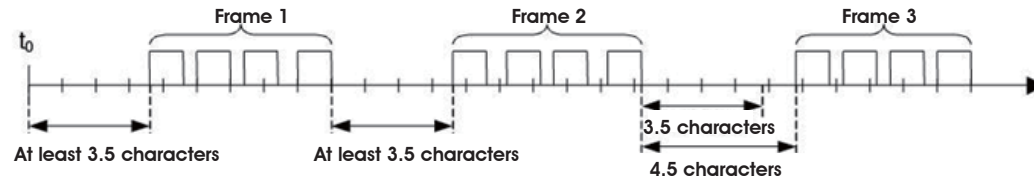

Starting	Address	Function code	Data	CRC check	End
≥ 3.5 characters	8 bit	8 bit	Nx8 bit	16 bit	≥ 3.5 characters

Figure 5: RTU message frame

The entire message frame must be sent in a continuous character stream.

When the pause time interval between two characters exceeds 1.5 characters, the information frame is considered incomplete and the receiver does not receive the information frame.

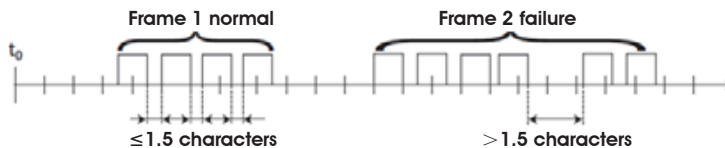

MODBUS RTU CRC Check

The RTU mode contains an error-detection domain based on a cyclic redundancy check (CRC) algorithm that performs on all message contents. The CRC domain checks the contents of the entire message and performs this check regardless of whether the message has a random parity check. The CRC domain contains a 16-bit value consisting of two 8-bit bytes. CRC16 check is adopted. Low bytes precede, high bytes precede.

Implementation of MODBUS RTU in Instrument

According to the official MODBUS definition, the command starts with a 3.5 character interval triggering command, and the end of the command is also represented by a 3.5 character interval. The device address and MODBUS function code have 8 bits. The data string contains $n \times 8$ bits, and the data string contains the starting address of the register and the number of read/write registers. CRC check is 16 bits.

Value	Start	Device address	Function	Data	Summary	Check	End
	No signal bytes during 3.5 characters	1-247 1	Function codes conforming to MODBUS specification	Data conforming to MODBUS specification	CRCL	CRCL	No signal bytes during 3.5 characters
Byte	3.5		1	n	1	1	3.5

Figure 7: MODBUS definition of data transmission

Instrument MODBUS RTU function code

The instrument only uses two MODBUS function codes:

0x03: Read-and-hold register

0x10: Write multiple registers

MODBUS Function Code 0x03: Read-and-hold Register

This function code is used to read the continuous block content of the holding register of the remote device. Request the PDU to specify the start register address and the number of registers. Address registers from zero. Therefore, the addressing register 1-16 is 0-15. The register data in the response information is packaged in two bytes per register. For each register, the first byte contains high bits and the second byte contains low bits.

Request	Function code	1 byte	0x03
	Start Address	2 byte	0x0000...0xffff
	Read register number	2 byte	1...125

Figure 8: Read-and-hold register request frame

Response	Function code	1 byte	0x03
	number of bytes	1 byte	$N \times 2$
	Register values	$N \times 2$ byte	

N = Register number

Figure 9: Read-and-hold register response frame

The following illustrates the request frame and response frame with the read and hold register 108-110 as an example. (The contents of register 108 are read-only, with two byte values of 0X022B, and the contents of register 109-110 are 0X0000 and 0X0064)

Request Frame		Response Frame	
Number Systems	(Hexadecimal)	Number Systems	(Hexadecimal)
Function code	0x03	Function code	0x03
Start address (high byte)	0x00	Byte count	0x06
Start address (low byte)	0x6B	Register Value (High Bytes) (108)	0x02
Number of Read Registers (High Bytes)	0x00	Register Value (Low Bytes) (108)	0x2B
Number of Read Registers (Low Bytes)	0x03	Register Value (High Bytes) (109)	0x00
		Register Value (Low Bytes) (109)	0x00
		Register Value (High Bytes) (110)	0x00
		Register Value (Low Bytes) (110)	0x64

Figure 10: Examples of read and hold register request and response frames

MODBUS function code 0x10: write multiple registers

This function code is used to write continuous registers to remote devices (1 ... 123 registers) block that specifies the value of the registers written in the request data frame. Data is packaged in two bytes per register. Response frame return function code, start address and number of registers written.

Request

Function code	1 byte	0x10
Start Address	2 byte	2 byte
Number of input registers	2 byte	2 byte
number of bytes	1 byte	1 byte
Register values	N×2 byte	N×2 byte

N = Register number

Figure 11: Write multiple register request frames

Response

Function code	1 byte	0x10
Start Address	2 byte	0x0000....0xffff
Register number	2 byte	1 ... 123(0x7B)

N = Register number

Figure 12: write multiple register response frames

The request frame and response frame are illustrated below in two registers that write the values 0x000A and 0x0102 to the start address of 2.

Request Frame	(Hexadecimal)	Response Frame	(Hexadecimal)
Number Systems	0x10	Number Systems	0x10
Function code	0x00	Function code	0x00
Start address (high byte)	0x01	Start address (high byte)	0x01
Start address (low byte)	0x00	Start address (low byte)	0x00
Input register number (high bytes)	0x02	Input register number (high bytes)	0x02
Input register number (low bytes)	0x04	Input register number (low bytes)	
number of bytes	0x00		
Register value (high byte)	0x0A		
Register value (low byte)	0x01		
Register value (high byte)	0x02		
Register value (low byte)			

Figure 13: Examples of writing multiple register request and response frames

Data format in instrument

Overview

Floating Point

Definition: Floating point, conforming to IEEE 754 (single precision)

Description	Symbol	Index	Mantissa	SUM
Bit	3	30...23	22...0	22...0
Index Deviation	127			

Figure 14: floating point single-precision definition (4 bytes, 2 MODBUS registers)

Example: Compile decimal 17.625 to binary

Step 1: Converting 17.625 in decimal form to a floating-point number in binary form, first finding the binary representation of the integer part

$$17_{\text{decimal}} = 16 + 1 = 1 \times 2^4 + 0 \times 2^3 + 0 \times 2^2 + 0 \times 2^1 + 1 \times 2^0$$

The binary representation of integer part 17 is 10001B

then the binary representation of decimal part is obtained

$$0.625 = 0.5 + 0.125 = 1 \times 2^{-1} + 0 \times 2^{-2} + 1 \times 2^{-3}$$

The binary representation of decimal part 0.625 is 0.101B.

So the binary floating point number of 17.625 in decimal form is 10001.101B

Step 2: Shift to find the exponent.

Move 10001.101B to the left until there is only one decimal point, resulting in 1.0001101B, and

10001.101B = 1.0001101 B × 2⁴. So the exponential part is 4, plus 127, it becomes 131, and its binary representation is 10000011B.

Step 3: Calculate the tail number

After removing 1 before the decimal point of 1.0001101B, the final number is 0001101B (because before the decimal point must be 1, so IEEE stipulates that only the decimal point behind can be recorded). For the important explanation of 23-bit mantissa, the first (i.e. hidden bit) is not compiled. Hidden bits are bits on the left side of the separator, which are usually set to 1 and suppressed.

Step 4: Symbol bit definition

The sign bit of positive number is 0, and the sign bit of negative number is 1, so the sign bit of 17.625 is 0.

Step 5: Convert to floating point number

1 bit symbol + 8 bit index + 23-bit mantissa

0 10000011 000110100000000000000000B (the hexadecimal system is shown as

0 x418d0000)

Reference code:

1. If the compiler used by the user has a library function that implements this function, the library function can be called directly, for example, using

C language, then you can directly call the C library function memcpy to obtain an integer representation of the floating-point storage format in memory.

For example: float floatdata; // converted floating point number

void* outdata; memcpy(outdata,&floatdata,4);

Suppose floatdata = 17.625

If it is a small-end storage mode, after executing the above statement, the data stored in the address unit outdata is 0x00.

Outdata + 1 stores data as 0x00

address unit (outdata + 2) stores data as 0x8D

address unit (outdata + 3) stores data as 0x41

If it is large-end storage mode, after executing the above statement,
the data stored in outdata of address unit is 0x41
Outdata + 1 stores data as 0x8D
address unit (outdata + 2) stores data as 0x00
address unit (outdata + 3) stores data as 0x00

2. If the compiler used by the user does not implement the library function of this function, the following functions can be used to achieve this function:

```
void memcpy(void *dest,void *src,int n)
{
char *pd = (char *)dest; char *ps = (char *)src;
for(int i=0;i<n;i++) *pd++ = *ps++;
}
```

And then make a call to the above memcpy(outdata,&floatdata,4);

Example: Compile binary floating-point number 0100 0010 0111 1011 0110 0110 0110 10B to decimal number

Step 1: Divide the binary floating-point number 0100 0010 0111 1011 0110 0110 0110B into symbol bit, exponential bit and mantissa bit.

0 10000100 11110110110011001100110B

1-bit sign + 8-bit index + 23-bit tail sign bit S: 0 denotes positive number

Index position E: $10000100B = 1 \times 2^7 + 0 \times 2^6 + 0 \times 2^5 + 0 \times 2^4 + 0 \times 2^3 + 1 \times 2^2 + 0 \times 2^1 + 0 \times 2^0$
 $= 128 + 0 + 0 + 0 + 0 + 4 + 0 + 0 = 132$

Mantissa bits M: $11110110110011001100110B = 8087142$

Step 2: Calculate the decimal number

$$D = (-1) \times (1.0 + M/2^{23}) \times 2^{-127}$$

$$= (-1)^0 \times (1.0 + 8087142/2^{23}) \times 2^{132-127}$$

$$= 1 \times 1.964062452316284 \times 32$$

$$= 62.85$$

Reference Code:

```
float floatTOdecimal(long int byte0, long int byte1, long int byte2, long int byte3)
{ long int realbyte0,realbyte1,realbyte2,realbyte3; char S;
long int E,M;
```

```
float D;
```

```
realbyte0 = byte3; realbyte1 = byte2; realbyte2 = byte1; realbyte3 = byte0;
```

```
if((realbyte0&0x80)==0)
{ S = 0;//positive number }
else { S = 1;//negative number }
E = ((realbyte0<<1)|(realbyte1&0x80)>>7)-127;
M = ((realbyte1&0x7f)<<16)|(realbyte2<<8)| realbyte3;
D = pow(-1,S)*(1.0 + M/pow(2,23))* pow(2,E);
```

```
return D; }
```

Function description: parameters byte0, byte1, byte2, byte3 represent 4 bytes of binary floating point number (

The decimal number converted from the return value

For example, the user sends the command to get the temperature value and dissolved oxygen value to the probe. The 4 bytes representing the temperature value in the received response frame are 0x00, 0x00, 0x8d and 0x41. Then the user can get the decimal number of the corresponding temperature value through the following call statement.

That is temperature = 17.625.

```
float temperature = floatTOdecimal( 0x00, 0x00, 0x8d, 0x41)
```

Read instruction mode

The communication protocol adopts MODBUS (RTU) protocol. The content and address of the communication can be changed according to the needs of customers.

The default configuration is network address 01, baud rate 9600, even check, one stop bit, users can set their own changes;

Function code 0x04: This function enables the host to obtain real-time measurements from slaves, which are specified as single-precision floating-point type (i.e. occupying two consecutive register addresses), and to mark the corresponding parameters with different register addresses.

Communication address is as follows:

0000-0001: Temperature value

0002-0003: Main Measured Value

0004-0005: Temperature and Voltage Value

0006-0007: Main Voltage Value

Communication examples:

Examples of function code 04 instructions:

Communication address = 1, temperature = 20.0, ion value = 10.0, temperature voltage = 100.0, ion voltage = 200.0

Host Send: 01 04 00 00 08 F1 CC

Slave Response: 01 04 10 00 41 A0 00 41 20 00 42 C8 00 43 48 81 E

Note:

[01] Represents the instrument communication address;

[04] Represents function code 04;

[10] represents 10H (16) byte data;

[00 00 00 41 A0] = 20.0; / temperature value

[00 00 41 20]= 10.0; // Main Measured Value

[00 00 42 C8] = 100.0; // Temperature and Voltage Value

[00 00 43 48] = 200.0; // Main measured voltage value

[81 E8] represents CRC16 check code;

Oxygen Saturation Table Under Different Temperatures

°C	mg/L	°C	mg/L	°C	mg/L
0	14.64	14	10.30	28	7.82
1	14.22	15	10.08	29	7.69
2	13.82	16	9.86	30	7.56
3	13.44	17	9.64	31	7.46
4	13.09	18	9.46	32	7.30
5	12.74	19	9.27	33	7.18
6	12.42	20	9.08	34	7.07
7	12.11	21	8.90	35	6.95
8	11.81	22	8.73	36	6.84
9	11.53	23	8.57	37	6.73
10	11.26	24	8.41	38	6.63
11	11.01	25	8.25	39	6.53
12	10.77	26	8.11		
13	10.53	27	7.96		

Note: this table is from appendix C of JJG291-1999.

The dissolved oxygen content can be calculated at different atmospheric pressures as follows.

$$A_s = \frac{P}{A \cdot 101.325}$$

In formular: A_s -- Solubility of atmospheric pressure at P(Pa); A-- Solubility at atmospheric pressure of 101.325(Pa);

P-- pressure, Pa.

Daily maintenance

According to the requirements of use, the installation position and working condition of the instrument are relatively complex. In order to make the instrument work normally, maintenance personnel need to carry out regular maintenance on the instrument. Please pay attention to the following matters during maintenance:

1. Please check whether the installation box of the instrument is leaking or not when it is installed outdoors;
2. Check the working environment of the instrument. If the temperature exceeds the rated range of the instrument, please take appropriate measures; otherwise, the instrument may be damaged or its service life may be reduced;
3. When cleaning the plastic shell of the instrument, please use a soft cloth and a soft cleaner to clean the shell. Be careful not to let moisture enter the inside of the instrument.
4. Check whether display data of the instrument is normal or not.
5. Check whether the wiring on the terminal of the instrument is firm. Pay attention to disconnect the AC power before removing the wiring cover.

Package Set

Product Description	Quantity
1) T6546 Fluorescence Online Dissolved Oxygen Meter	1
2) Instrument Installation Accessories	1
3) Operating Manual	1
4) Qualification Certificate	1

Note: Please check the complete set of instruments before use.
The company's other series of analytical instruments, please login to our website for enquiries.

Warranty

Our company guarantees that there will be no significant deviation in material and process of this product within one year from the date of purchase.

During the warranty period, if necessary repair is not caused by improper use or misoperation, please pay the transportation fee to return the instrument, and we will repair it free of charge.

Our customer service department will confirm whether the product problem is caused by the deviation of the product itself or the improper use of the customer.

Product repair beyond the warranty period will be on the basis of replacement.

A fixed fee will be charged.

The above warranties are our only valid warranties and supersede all other warranties, express or implied, including any implied, unrestricted warranties of merchantability or fitness for a particular purpose.

We shall not be responsible for any loss, compensation, expense or damage caused by the negligence or other ACTS of the buyer or any third party.

In no event shall our liability, whatever the cause of action, exceed the cost of the product in question, whether based on contract, warranty, indemnity or infringement (including negligence).

Product repair for any reason must be submitted in the form of repair card (RIR) and approved by our customer Service department before returning.

When applying for repair approval, the name, quantity and reason of the repaired goods must be clearly stated. The repaired goods must be carefully packed to avoid damage in transit and insured. We are not responsible for any damage caused by poor packing.

When the product is repaired, the original packaging of the instrument should be used; otherwise, it should be wrapped in bubble bag and then wrapped in corrugated paper box, preferably with a brief explanation of the fault to facilitate the customer service department to repair the product.

Notes

Distinguished users, please pay attention to the following points when using the instrument, in order to ensure the life and accuracy of the instrument.

- ★ Careful handling to avoid collision and falling instruments in use.
- ★ Avoid contact with water or other liquids during use.
- ★ Don't put the instrument in the sunshine for a long time. After use, it should be stored in a cool, dry and ventilated place.
- ★ If you don't use the instrument for a long time, you should unplug the power supply to avoid accidents.
- ★ This instrument is not suitable for use in harsh environment, high temperature, low temperature or strong magnetic field interference, which may lead to instrument damage.
- ★ If there is any problem with the instrument, please contact the dealer or the company. Do not disassemble the instrument by yourself. If disassembled, the company will no longer be responsible for the warranty.



上海淳业仪表科技有限公司

Shanghai Chunye Instrument Technology Co.,Ltd

Tel: 021-61621082

Fax: 021-61621099

Web: www.twinno.net

Add: Building 6, No.166 Mindong Road, Pudong
New District, Shanghai, China Post code:201209
